



Direct Connection Performance Part

REDEYE CYLINDER HEADS

PART NUMBER: 77072534AB

2015+ HELLCAT (6.2L)

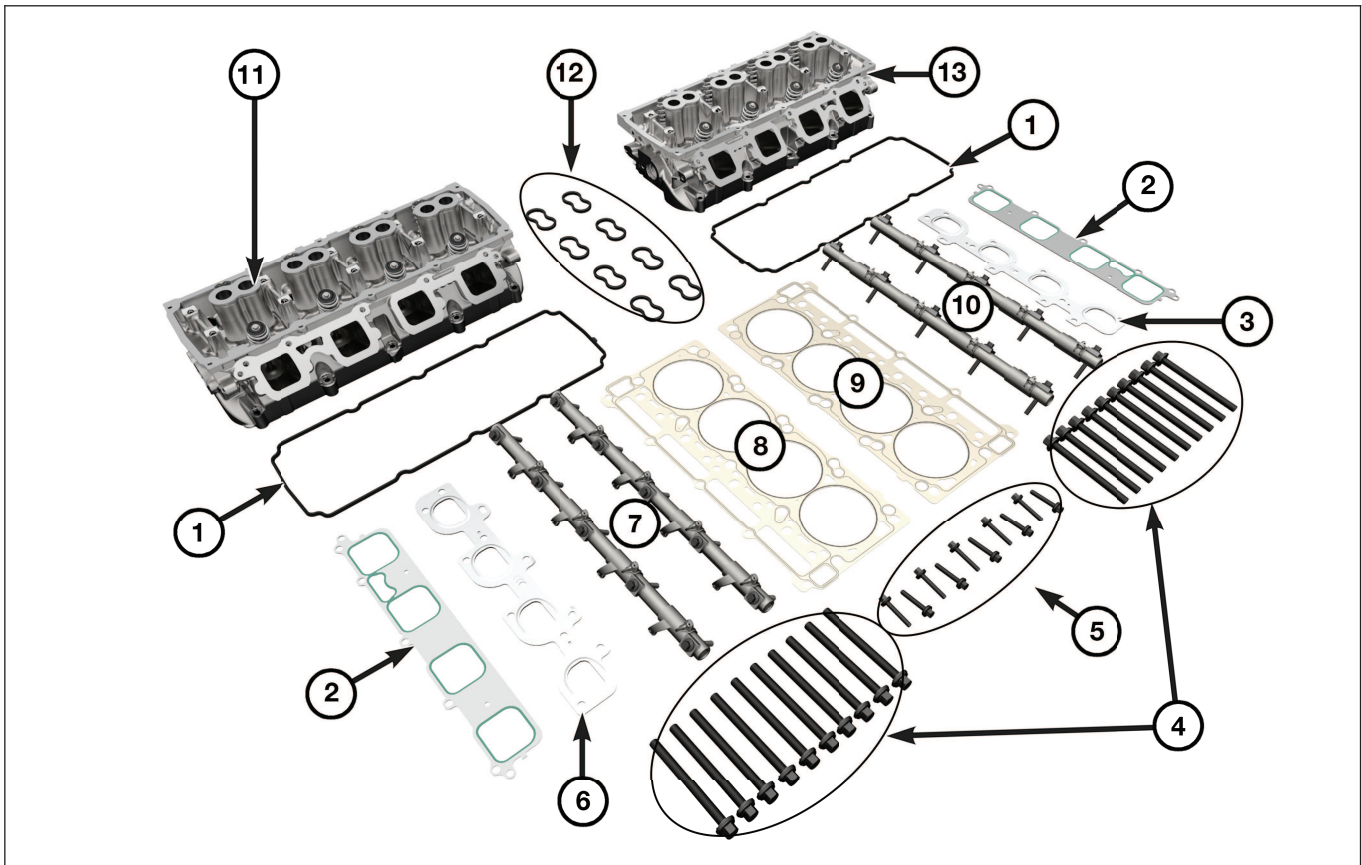

| Item | Description | Part Number | Quantity |
|------|--------------------------|-------------|----------|
| 1 | Valve Cover Gasket | 05114179AB | 2 |
| 2 | Intake Gasket Set | 68271246AA | 1 |
| 3 | Exhaust Gasket - R | 05038098AA | 1 |
| 4 | Head Bolt M12x1.5x135 | 06510280AA | 20 |
| 5 | Head Bolt M8x1.25x45 | 06506334AA | 10 |
| 6 | Exhaust Gasket - L | 05038099AA | 1 |

| Item | Description | Part Number | Quantity |
|------|-----------------------------------|-------------|----------|
| 7 | Exhaust Rocker System | 53021553AB | 2 |
| 8 | Cylinder Head Gasket - L | 68164696AE | 1 |
| 9 | Cylinder Head Gasket - R | 68164621AE | 1 |
| 10 | Intake Rocker System | 53021552AB | 2 |
| 11 | Cylinder Head Complete Redeye - L | 53010853AD | 1 |
| 12 | Spark Plug O-Ring | 53021569AD | 8 |
| 13 | Cylinder Head Complete Redeye - R | 53010852AD | 1 |

NOTE: Some items may be shipped with more than the quantity needed to perform the procedure.

| Description | Capacities | Type |
|------------------------|---|--|
| Engine Oil With Filter | 7 Quarts / 6.6 Liters | The manufacturer recommends the use of Pennzoil Ultra 0W-40 or equivalent MOPAR engine oil meeting the requirements of FCA Material Standard MS-12633 for use in all operating temperatures. We recommend you use MOPAR Engine Oil Filters. |
| Cooling System * | 15.2 Quarts / 14.4 Liters Intercooler 4.5 Quarts / 4.2 Liters | Engine/Intercooler Coolant We recommend you use MOPAR Antifreeze/Coolant 10 Year/150,000 Mile Formula OAT coolant conforming to MS.90032. |
| Spark Plugs | GAP .043 in / 1.10 mm | We recommend you use MOPAR Spark Plugs. |

* Includes heater and coolant reservoir filled to MAX level.

Tools Required

| Description | Part Number |
|---|-------------|
| Retainer, Push Rod | 9070 |
| TO PURCHASE GENUINE MOPAR® SPECIAL TOOLS, PLEASE VISIT: WWW.MOPARESENTIALTOOLS.COM | |

PLEASE READ ALL INSTRUCTIONS PRIOR TO INSTALLATION.
FOR ASSISTANCE CONTACT DIRECT CONNECTION TECH HOTLINE 1-800-998-1110

CYLINDER HEAD REMOVAL

First, perform the fuel system pressure release procedure:

WARNING! The fuel system is under constant high pressure even with engine off. Until the fuel pressure has been properly released from the system, do not attempt to open the fuel system. Do not smoke or use open flames/sparks when servicing the fuel system. Wear protective clothing and eye protection. Make sure the area in which the vehicle is being serviced is in a well ventilated area and free of flames/sparks.

Failure to comply may result in serious or fatal injury.

- Remove the fuel pump relay from the Power Distribution Center (PDC). A relay location label can also be found on the underside of the PDC cover.
- Start and run the engine until it stalls.
- Attempt restarting engine until it will no longer run.
- Turn the ignition to the OFF position.
- Return fuel pump relay to the Power Distribution Center (PDC).

NOTE: After servicing the fuel system, one or more Diagnostic Trouble Codes (DTC's) may have been stored in the Powertrain Control Module (PCM) memory due to disconnecting the fuel pump module circuit. A diagnostic scan tool must be used to erase a DTC.

1. Disconnect and isolate the negative battery cable.
2. Drain engine coolant system.

WARNING! Do not remove cylinder block drain plugs or loosen radiator draincock with system hot and under pressure. Serious burns from coolant can occur. DO NOT WASTE reusable coolant. If solution is clean, drain coolant into a clean container for reuse.

- 1) Remove radiator pressure cap.
 - 2) If equipped, remove the underbody splash shield.
 - 3) Loosen radiator petcock.
 - 4) Drain coolant into a clean container.
 - 5) If necessary, to perform a complete coolant drain of the engine, remove the drain plug from the engine block.
3. Remove the supercharger assembly:
 - 1) Drain the low temperature cooling system.
 - 2) Remove all necessary components, hoses, lines, and electrical connections for supercharger removal.

NOTE: Mark Low Temperature Radiator (LTR) circuit hoses to coolant crossover for correct reassembly.

- 3) Remove the supercharger to cylinder head retaining bolts, starting with number ten, going backwards to number one.

NOTE: The supercharger assembly will require the help of an assistant(s) to lift from the engine compartment.

- 4) Lift the supercharger upward to disengage the dowels which align the supercharger to the right cylinder head.
4. Remove the catalytic converters.
5. Remove the power steering pump (or idler pulley if equipped with electric power steering), supercharger idler pulley assembly, and any other necessary accessory drive(s)/bracket(s) from the cylinder heads.

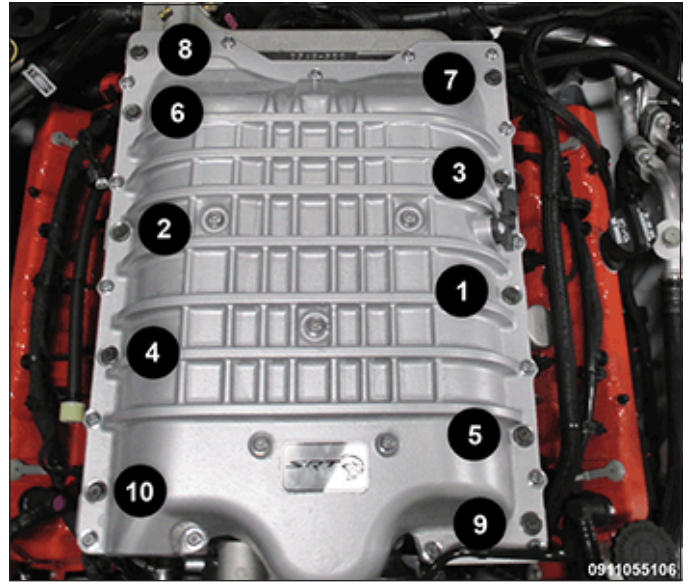

NOTE: It is not necessary to remove the power steering hoses if equipped with hydraulic power steering.

6. Remove the ignition coils and position harness aside.
7. Remove the spark plugs.
8. Using the sequence shown, remove the left and right side cylinder head cover retaining bolts.

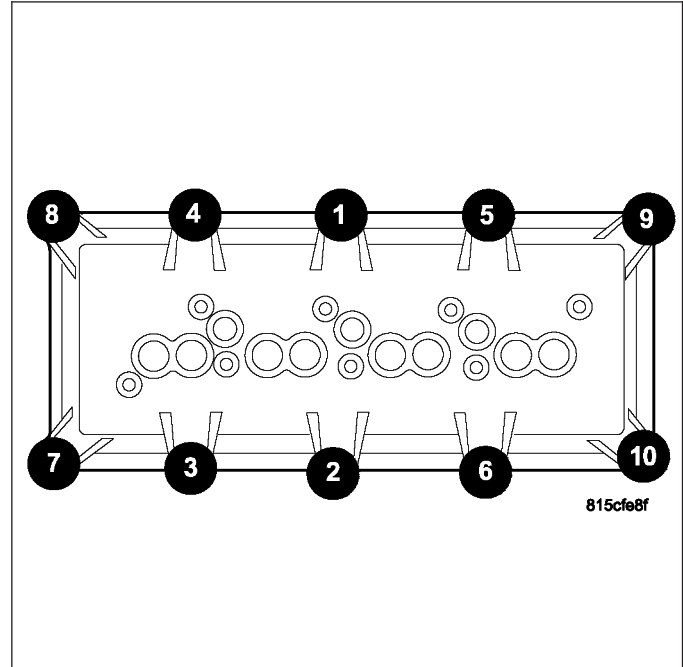

9. Remove the cylinder head covers.

10. Remove the rocker shaft assemblies and push rods:

1) Install Push Rod Retainer 9070.

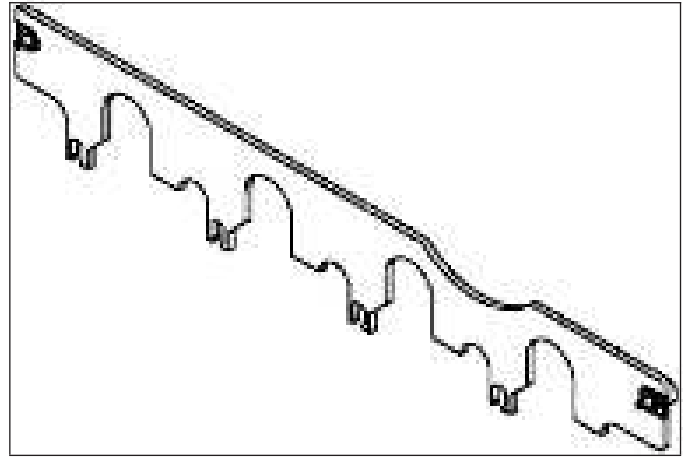

2) Using the sequence shown, loosen the rocker shaft assemblies.

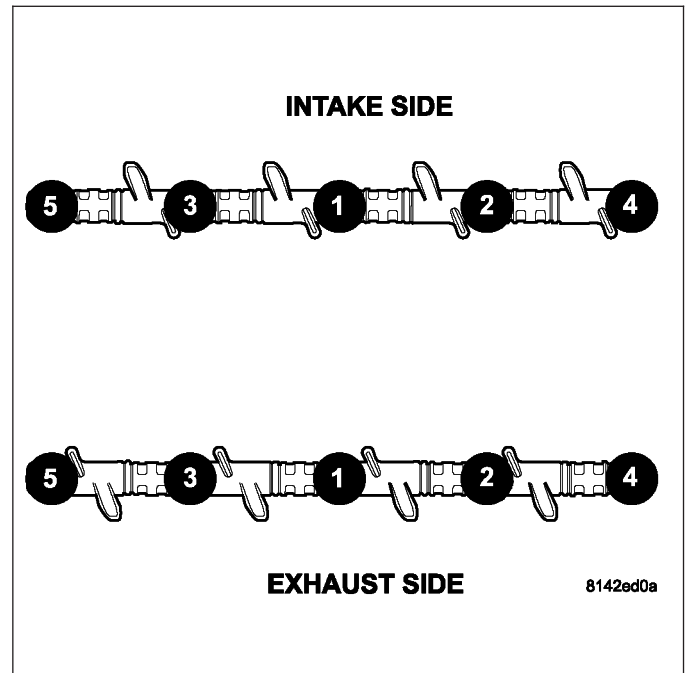

3) Remove the rocker shaft assemblies.

4) Remove the push rods. Note the push rod location for reassembly.

NOTE: Do not remove the retainers on the rocker shaft bolts (2) from the rocker shaft assemblies (3). The assembly tangs (1) at the bottom of the retainers can be damaged, causing the assembly tangs to break off and get into the engine.

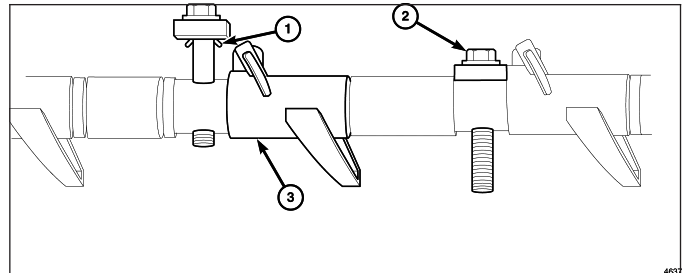

NOTE: It is not necessary to remove the exhaust manifolds to remove the cylinder heads.

- Using the sequence shown, remove the cylinder head bolts and remove the cylinder head(s).

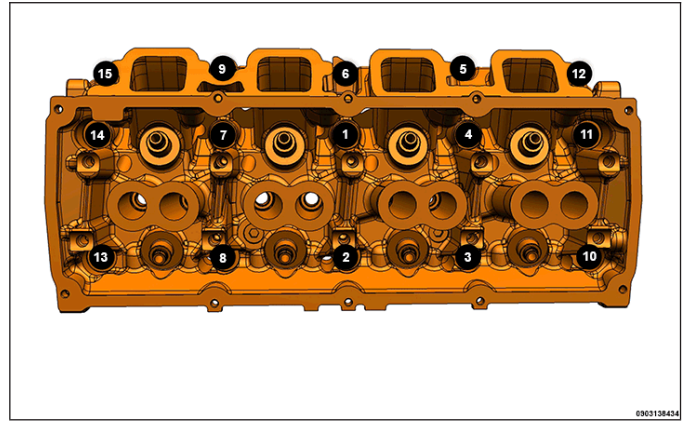

- Remove the exhaust manifold bolts using the exhaust manifold retaining bolt sequence shown below, starting at eight and going backwards.

CYLINDER HEAD INSTALLATION

- Using the included exhaust manifold gasket(s), position the exhaust manifold(s) and install the retaining bolts finger tight.
- Using the exhaust manifold retaining bolt sequence shown, torque the exhaust manifold retaining bolts to **25 N·m (18 Ft. Lbs.)**.

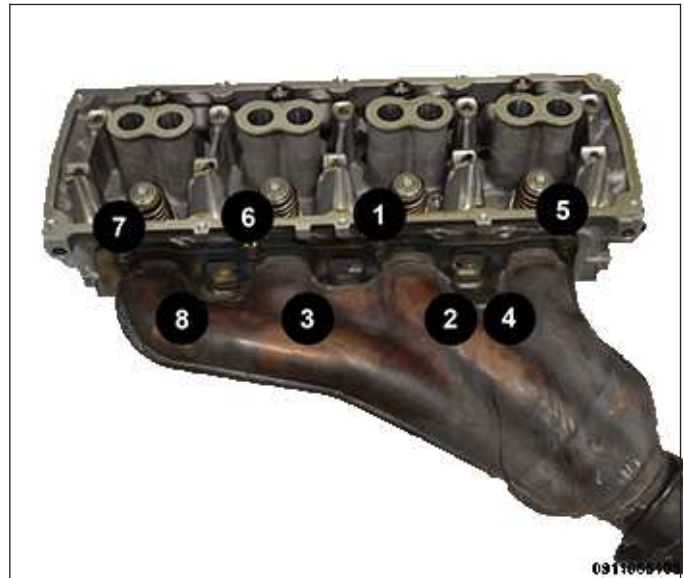

NOTE: The cylinder head gaskets are not interchangeable between left and right sides. They are marked "T" for top, "B" for bottom, "L" for left side and "R" for right side.

- Clean all sealing surfaces of the engine block and the cylinder head(s).

NOTE: Rotate crankshaft 45° so that all pistons are 1/2 the way down the cylinder bore to avoid piston to valve contact.

4. Position the new cylinder head gasket(s) (1) onto the engine block.
5. Position the cylinder head(s) (2) onto the engine block.
6. Install the cylinder head bolts finger tight.

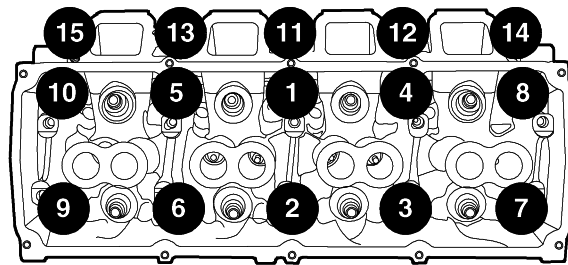
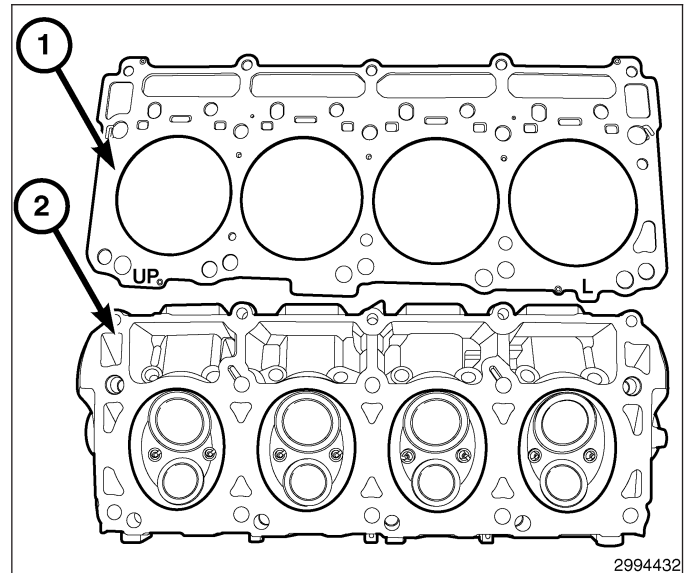

88745

7. Using the cylinder head retaining bolt sequence shown, torque the retaining bolts.
 - a. Using the sequence shown, torque bolts 1-10 to **34 N·m (25 ft. lbs.)**.
 - b. Using the sequence shown, torque bolts 11-15 to **20 N·m (15 ft. lbs.)**.
 - c. Using the sequence shown, torque bolts 1-10 to **54 N·m (40 ft. lbs.)**.
 - d. Using the sequence shown, verify bolts 11-15 are **20 N·m (15 ft. lbs.)**.
 - e. Using the sequence shown, torque bolts 1-10 to **61 N·m (45 ft. lbs.)**.
 - f. Using the sequence shown, rotate bolts 1-10 **160 degrees**.
 - g. Using the sequence shown, torque bolts 11-15 to **28 N·m (21 ft. lbs.)**.

8. Install the push rods and rocker shaft assemblies:

NOTE:

- The longer pushrods are for the exhaust side, and the shorter pushrods are for intake side.
- Ensure the retainers and rocker arms are not overlapped when torquing bolts.
- Verify the push rods are installed into the rocker arms and lifters correctly while installing the rocker shaft assembly. Recheck after the rocker shaft assembly has been torqued to specification.

- 1) Install the pushrods in the same order as removed.
- 2) Install the rocker shaft assemblies in the correct location.

NOTE: The rocker shaft assemblies are not interchangeable between intake and exhaust. The intake rocker arms are marked with the letter "I".

- 3) Using the sequence shown, torque the rocker shaft bolts as follows:
 - Snug to **10 N·m (7 ft. lbs.)**.
 - Torque to **23 N·m (17 ft. lbs.)**.
 - Individually loosen by 1/2 turn and re-torque to **23 N·m (17 ft. lbs.)**.
 - Finally, **Rotate 30 degrees**
 - **Repeat torque sequence several times to ensure rocker shaft assembly is firmly seated.**

NOTE: Do not rotate or crank the engine during or immediately after rocker arm installation. Allow the hydraulic roller lifters adequate time to bleed down (about 5 minutes).

9. Install the power steering pump (or idler pulley if equipped with electric power steering) and supercharger idler pulley assembly.

10. Install the catalytic converters.

11. Install the left and right cylinder head covers and hand start all fasteners.

CAUTION! Do not allow other components including the wire harness to rest on or against the engine cylinder head cover. Prolonged contact with other objects may wear a hole in the cylinder head cover.

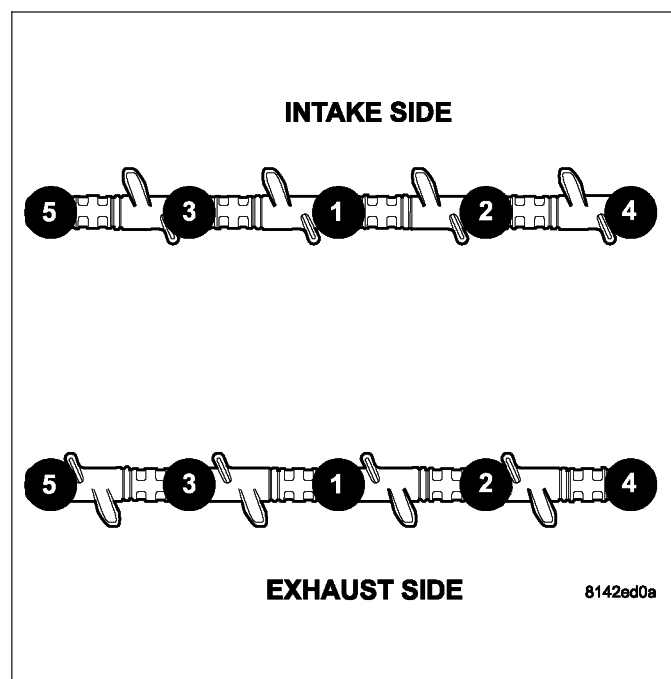

12. Using the sequence shown, torque the cylinder head cover bolts to **12 N·m (9 Ft. Lbs.)**.

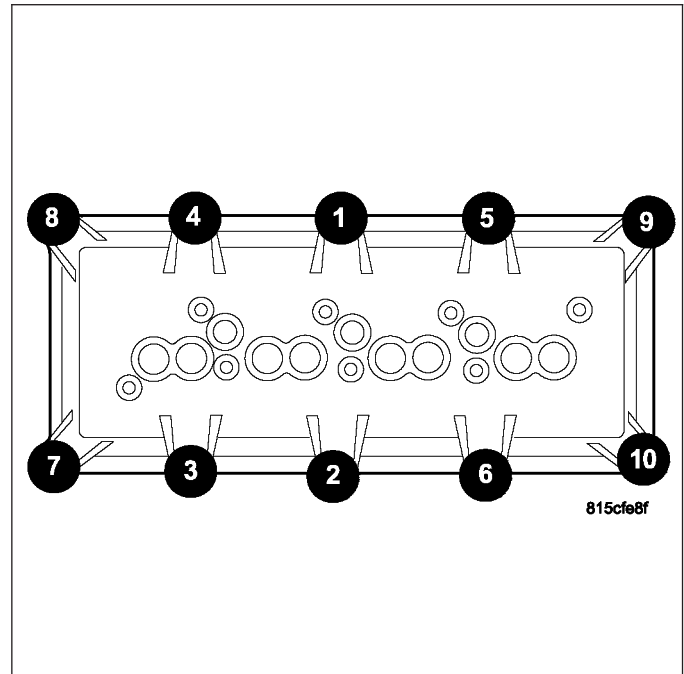

13. Install the spark plugs and torque to **25 N·m (18 Ft. Lbs.)**
14. Install the ignition coils and ignition coil wire harness. Torque ignition coils to **7 N·m (62 In. Lbs.)**
15. Install the supercharger assembly:
- 1) Inspect the seals and replace if necessary.
 - 2) Position the supercharger assembly onto the cylinder heads, aligning the dowels in the supercharger with the holes in the right cylinder head.
 - 3) Using the sequence shown, Install the supercharger retaining bolts and torque all retaining bolts as follows:
 - First torque all bolts, using the sequence, to **5 N·m (4 ft. lbs.)**.
 - Next torque all bolts, using the sequence, to **15 N·m (11 ft. lbs.)**.
 - Finally torque all bolts, using the sequence, to **30 N·m (22 ft. lbs.)**.

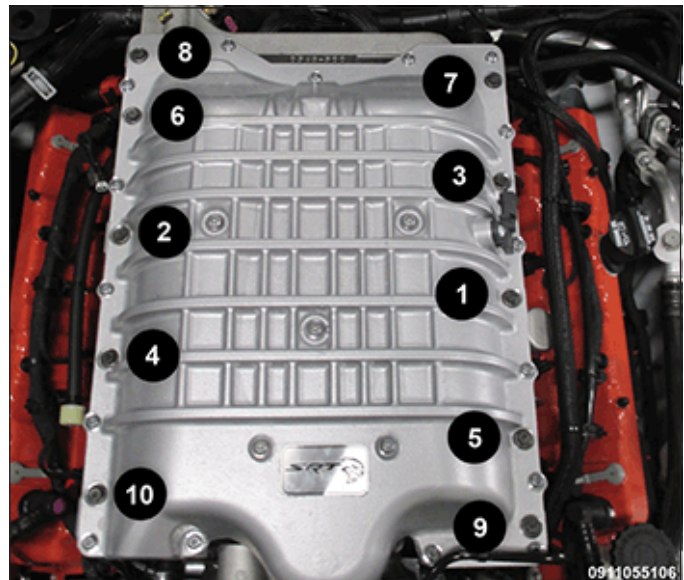

- 4) Install all components, hoses, lines, and electrical connections that were removed/disconnected during supercharger removal.

NOTE: Install the Low Temperature Radiator (LTR) circuit hoses to coolant crossover (1). Use previous markings to determine hose location.

16. Fill the low temperature cooling system and engine coolant system.

NOTE: Evacuating or purging air from the charge air cooling system must be done with the use of a pressurized air operated vacuum generator.

17. Perform engine oil service.
18. Connect the negative battery cable.
19. Start engine check for leaks.

